



Typ / Type : UNO-67-500-6 E		Art.-Nr. / Art.-No. : F08-50010	
U	230V (50Hz)	Δp_{fa} min	– Pa
P ₁	0.56 kW	ΔI	5 %
I _N	2.70 A	I _A / I _N	2.2
n	900 min ⁻¹		IP54
C _{400V}	12 μ F		01.024
t _R	50 °C		57 kg

--- Kennlinie bei Nennspannung; bei axialer Durchströmung der Unobox / performance curve at rated voltage; at axial air flow in Unobox

LWArel A-bewertet bei $V=0,5 \cdot V_{max}$ LWArel A-weighted at $V=0,5 \cdot V_{max}$		fM [Hz]						
		125	250	500	1K	2K	4K	8K
LWA2 [dB(A)]	Gehäuse / casing	-3	-4	-13	-15	-18	-23	-30
LWA5 [dB(A)]	Ansaugseite / inlet side	-12	-8	-3	-5	-6	-11	-22
LWA6 [dB(A)]	Ausblasseite / outlet side	-17	-15	-5	-4	-7	-15	-25

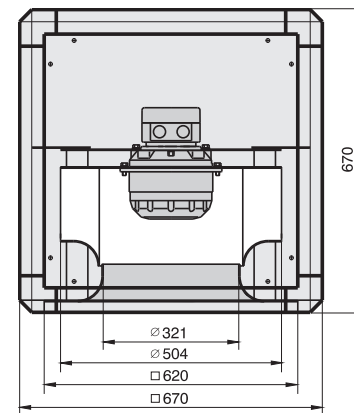

U₁ braun / brown
 U₂ blau / blue
 Z₁ schwarz / black
 Z₂ orange / orange
 TB weiß / white
 PE gelb-grün / yellow-green